

Activities for PAGGS badge

In danish scouting we do a lot of cooking over open fire. We give you a recipe for a traditional danish meal that is often made at danish scoutcamps. The main course is *frikadeller* serve them with boiled potatoes (with or without skin) and some salad. For dessert a traditional danish applecake (*rå æblekage*) that doesn't need heating. There is also some recepies for traditional danish christmasdinner usually eaten on christmas evening and at our christmas week-end by the scouts. The meat is usually *flæskesteg* (pork) and/or *and/gås* (duck/goose) it is served with *hvide* and *brune kartofler* (white and brown potaoes), *rødkål* (red cabbage) and apples. For dessert we eat *ris á l'amande* (f rench name for a danish dish). Usually we put one hole almond in the *ris á l'amonde*, who ever finds it gets a smal gift (could be a marzipan pig). Most people try to hide that they found the almond and every body else is trying to guess who has got it. After dinner we dance around the Christmas-tree singing christmas songs and afterwards we open the presents form under the tree and eat cookies (*vanillekranse*, *brunkager* and *pebernødder*)

In scouting we also do a lot of orienteering. You will here find some directions about how to find your way without a compass.

Below you find some suggestions of how to use these activities for your scouting at home.

Make a traditional danish scout meal.

Do your cooking on open fire. Make frikadeller with boiled potatos and salat. For dessert make æblekage.

When you have finished your meal you can use the fire for an evening by the camp fire.

Do a Danish mini Christmas.

1. Make some Danish Christmas decorations. Fx. a plaited heart and/or star. (See *decoration instructions*).
2. Bake some of the typical Danish Christmas cakes/cookies. (See *Danish recipes*).
3. Make a Danish Christmas dinner consisting of fx. *flæskesteg*, *white* and/or *brown potatoes* and *ris á l'amande*. If you want you can make goose or duck also. (See *Danish recipes*).
4. Play the Danish Christmas game *mus* (mouse). (See *Christmas games*).
5. Dance around the Christmas tree singing "Glade jul"

Orienteering

Find your way without a compass.

If you're lost in Denmark there are several ways to get back on the track even though you have no compass.

Some ways to find the four points of the compass without having one:

At daytime

Church towers are almost always towards the West.
The chancel / choir of a church is most often to the East.
Standard trees often lean towards the East because of the west wind.
Treetops are usually most developed towards the South.
Trees and stones have moss on the shady side, often the North side.
Anthills are normally found to the South of the tree trunk.
At noon the sun is due South.
At 6am. the sun is due East.
At 6pm. the sun is due West.

At night

At night the North Star shows – curiously enough – North.
And the lit part of the moon shows you in which direction the sun is hiding and knowing that you can find the points of the compass.
When the moon is waxing, it's towards the North at 6am, East at noon, South at 6pm. and West at midnight.
When the moon is full, it's towards the North at noon, East at 6pm, South at midnight, and West at 6am.
When the moon is on the wane, it's towards the North at 6pm, East at midnight, South at 6am. and West at noon.
When the moon is new, it's towards the North at midnight, East at 6am, South at noon, and West at 6pm.

Your watch

You can use your watch as a compass. Hold your watch horizontally. The hour hand has to point towards the sun. With a straw or something else you half the angle between the hour hand and 12 o'clock. The straw now points South – North.

Knowing this you shouldn't get lost while in Denmark, but are all these guide lines also valid in your country? Try them out!

Games

Ask a danish scout how to play bordergame, tail game, scoutball or soap bungee.
Try out some Kim's games (binoculars, taste, smell, poridge)

Crafts

Make "the little mermaid" in clay

Pioneering

Do some pioneering. Things often done in Gladsaxe are: 10 minutes tower, dinnertable, catapult, romersk stirrsvogn (chariot race). We will later add some sketches to this document for you to follow.

Danish recipes

Frikadeller (4 pers.)

250 g ground beef
250 g pound ground pork
1 finely chopped onion
3 tabelspoons flour
1 egg
2-3 dl milk
salt, pepper
oil or butter- for frying

Mix together the beef and pork; add onion, pepper, salt, flour and eggs. Add milk little by little. Put it in the refrigerator for ½ an hour. Add some more milk so you can form meat mixture into balls. Fry the meatballs aprox. 10 min. turn over often so they don't get to dark.

Rå æblekage (4-6 pers)

500 g apples
evt. ½ l water
evt. 75-100 g sugar
75 g dry breadcrumbs
50 g sugar
50 g butter
2 dl whipping cream
redcurrant jelly

The apples can be used raw in that case just grate them or the can be cooked. Peel the apples boil them in a bit of water till they are done stir them and add some sugar. Let it cool of.

Melt butter in a pan, add sugar and breadcrumbs keep stiring untill slightly brow. Take it of the heat, keep stiring on and off until fully cooled off.

Put apples and breadcrumbs layerwise in a bowl. The toplayer should be breadcrumbs.

Whip the am and put in op top. Finish off with some jelly. Serve cool.

You can also use the hot breadcrumbs and cold appls, but then you have to serve it right away.

Flæsketeg (6 - 8 pers)

1 ½ kg loin of pork with rind
Salt
Pepper
Bay leefs

Score the pork and rub with salt Plase whole pepper and bay leefs in the rind. Place the pork on grid in a roasting pan. The rind should be horizontal, you can korrekt with a piece of alu

foil. Add water to pan while roasting

Put it in a cold oven. Turn it to 200° C for about 1½ hour. When the meat thermometer shows 55° C check whether the rind is crisp. If so keep on heating til 65°, if not turn the oven heat to 250-300° C and keep heating til the pork reaches 65 °C. Add 1 - 2 cups boiling water to pan while roasting.

Skim drippings for fat and thicken with cornstarch add salt and pepper to taste.

Brune kartofler (6-8 pers)

1 kg small round potatoes (boiled)

150 g sugar

ca. 1 dl water

Add everything to a frying pan. Let the water cook off while stirring, at some point the sugar start to caramelize keep stirring for a while until all potatoes are covered but stop before the caramel turns black. Serve hot.

Hvide kartofler (6-8 pers.)

1½ kg potatoes

salt

water

Boil the potatoes for about 15-20 min. serve warm without skin.

Rødkål (8 pers)

1 medium head red cabbage

1 rounded tablespoon shortening

1/2 cup vinegar or lemon juice

1 teaspoon salt

1/4 cup sugar

1/4 cup currant jelly

Shred cabbage very fine. Melt shortening in large kettle (or pot); add cabbage, vinegar or lemon juice, salt and sugar. Cook gently until tender, then season to taste with additional salt, sugar, vinegar or lemon juice, or currant jelly.

Ris à l'amande

65 g pudding rice

½ l milk

½ vanilla pod

25 g sugar

50 g chopped almonds

canned or bottled cherries

Cook the rice in the milk until tender, together with the vanilla pod cut open. Let cool. Stir in sugar and almonds. fold in whipped cream. Serve cold with slightly heated preserved cherries.

Brunkager

It is recommended to make the dough a couple of days before the actual baking.

- 450 g syrup
- 250 g butter
- 250 g brown sugar
- 25g bitter orange peel
- 1 tablesp. cinnamon
- 1 tablesp. ground cloves
- ½ teasp. cardamom
- 1 teasp. baking powder
- 2 tablesp. rosewater
- 1 kg flour
- Almonds

Warm the syrup in a saucepan, add the butter, orange peel, spices and sugar. Stir in the baking powder, dissolved in the rosewater. Gradually add the flour, kneading thoroughly after each addition. Turn into a bowl, cover with a cloth and keep cold.

Before baking, roll out thinly and cut into rounds. Place well apart on a greased baking-sheet, brush with water and decorate with sliced almonds. Bake for 8-10 min. at 200° C.

Pebernødder (about 95 pebbernødder)

- 250 g flour
- 175 g butter
- ½ teaspoon white pepper
- 1 teaspoon vanilla sugar
- 125 g sugar
- peel from ½ lemon, grated

Workbutter and together. Add pepper, vanilla sugar, sugar a, put it all together. Roll in tiny balls about the size of hazel nuts. Bake in the top of the oven 8-10 minutes at 200°C.

Vanillekranse (about 100)

- 250g flour
- ½ teaspoon ammonium carbonate
- vanilla from 1 pod (only the grain from inside, scrape it out with a knife)
- 50 g finely chopped almonds
- 200 g butter
- 125 g sugar
- ½ egg

Mix flour, ammonium carbonate, vanilla and almonds. Mix in the butter and add sugar. Work it together with the egg.

Leave the dough in a cool place for at least half an hour.

Put dough in cookie press and press out onto greased cookie sheet in small wreaths (4 cm diameter). Or roll them by hand.

Bake in the top of the oven about 8 min. at 200°C.

Orienteering (How to find your way without a compass)

If you're lost in Denmark there are several ways to get back on the track even though you have no compass.

Some ways to find the four points of the compass without having one:

At daytime

Church towers are almost always towards the West.

The chancel / choir of a church is most often to the East.

Standard trees often lean towards the East because of the west wind.

Treetops are usually most developed towards the South.

Trees and stones have moss on the shady side, often the North side.

Anthills are normally found to the South of the tree trunk.

At noon the sun is due South.

At 6am. the sun is due East.

At 6pm. the sun is due West.

At night

At night the North Star shows – curiously enough – North.

And the lit part of the moon shows you in which direction the sun is hiding and knowing that you can find the points of the compass.

When the moon is waxing, it's towards the North at 6am, East at noon, South at 6pm. and West at midnight.

When the moon is full, it's towards the North at noon, East at 6pm, South at midnight, and West at 6am.

When the moon is on the wane, it's towards the North at 6pm, East at midnight, South at 6am. and West at noon.

When the moon is new, it's towards the North at midnight, East at 6am, South at noon, and West at 6pm.

Your watch

You can use your watch as a compass. Hold your watch horizontally. The hour hand has to point towards the sun. With a straw or something else you half the angle between the hour hand and 12 o'clock. The straw now points South – North.

Knowing this you shouldn't get lost while in Denmark, but are all these guide lines also valid in your country? Try them out!

Christmas games

Mus (mouse):

This is a classical Christmas game where you get to eat a lot of pebernødder (see *danish recipies*).

How to play:

One can use a chessboard or something like it for this games but it is not nessasary. You place a pebernød in each square and send one of the 2 players out for a moment.

The other players now choose one pebernød that is the mouse.

The person outside the door should now eat as many pebernødder (pebernød in plural) without choosing the mouse.

The person choose one pebernød at the time. If its not the mouse that is chosen he/she can eat it but if it is the mouse the other players shout: "MOUSE!!!". And the next player has to go out the a mouse has to be chosen.

The game is repeated until there is no more pebernødder or no one can eat any more.

The game can be played 2 to 20 players. If many players the leader or one that is not int the game can chose 10 "mice" and the game can go on until all mice has been found or all pebernødder has been eaten.

Pakkeleg (gift game):

Fun game with small presents.

How to play:

All players brought a gift. It can be small fun, cheap things. The players sits around a table. All the gifts are placed in the middle of the table. One or more dices are use.

The players take turns to throw the dice. If you get a 6 you can take a gift.

When all the gifts are gone taken a timer is set for fx. 15min.

The players now continue to take turns to throw the dice. If you get a 6 you can take a gift from one of the other players. When the time is up you get to keep the gifts you have.

The game can be extended: If you get a 1 you have to give a present to the player to your left and if you get a 3 you can take a gift from the player on your right.

At pakke en gave ind med én hånd (to wrap a gift with 1 hand):

Each team consists of 2 people. Each person can use only 1 arm.

How to play:

The teams hold eachothers hands one their backs.

The team that first get to wrap their present is the winner. Ofcause the presents has to be wrapped nicely with curly band and a bow.

Lag på lag (layer onto layer):

A present is wrapped into many layers of paper. The players take turns to throw a dice. If you get a 6 you can unwrap 1 layer of paper.

If you are the one to unwrap the last layer you have win the present.

Christmas song

Glade jul (Silent night)

Glade jul, dejlige jul,
engle daler ned i skjul!
Hid de flyver med paradigrønt,
hvor de ser, hvad for Gud er kønt,
lønlig iblandt os de går,
- lønlig iblandt os de går!



Julefryd, evige fryd,
hellig sang med himmelsk lyd!
Det er englene, hyrderne så,
dengang Herren i krybben lå,
evig er englenes sang,
- evig er englenes sang.

Fred på jord, fryd på jord,
Jesusbarnet blandt os bor!
Engle sjunger om barnet så smukt,
han har Himmerigs dør oplukt,
salig er englenes sang,
- salig er englenes sang.

Salig fred, himmelsk fred
toner julenat herved!
Engle bringer til store og små
bud om ham, som i krybben lå;
fryd dig, hver sjæl, han har frelst,
- fryd dig, hver sjæl, han har frelst!

Christmas decorations

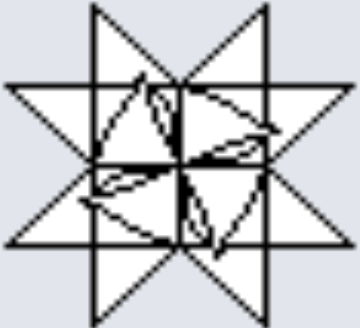
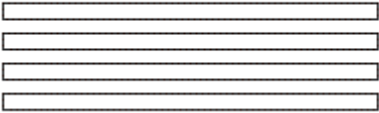
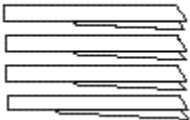
The plaited star

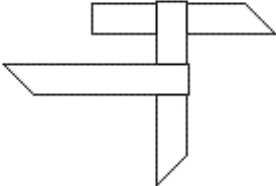
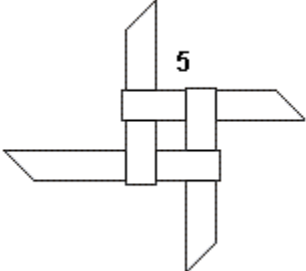
	<p>The star seen from front.</p>
<p>1</p> 	<p>1 Cut 4 strips in paper - each about 30 cm long. It is important that the strips is evenly in width.</p>
<p>2</p> 	<p>2 Fold them in the middle and cut the ends slanted.</p>
<p>3</p> 	<p>3 Hold the first strip horisontal and hang the other strip over.</p>
<p>4</p> 	<p>4 The third strip is hung over the other.</p>
<p>5</p> 	<p>5 The forth strip is hung over the forth strip and the ends is put through the eye of the first strip.</p>

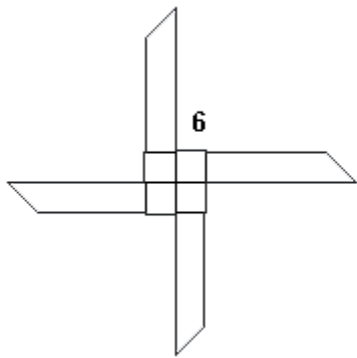

6 Plait the 4 strips in the others so that they make a square. Push them as close together as possible. The slanted ends should point the same way, as in the picture, to make it easy for yourself further in the plaiting.

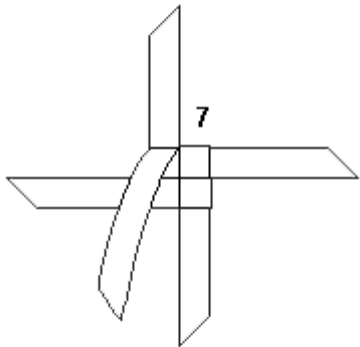

7 Bend one half of the first strip as shown.

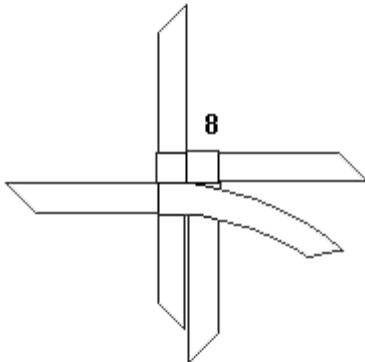

8 Continue with the second strip.

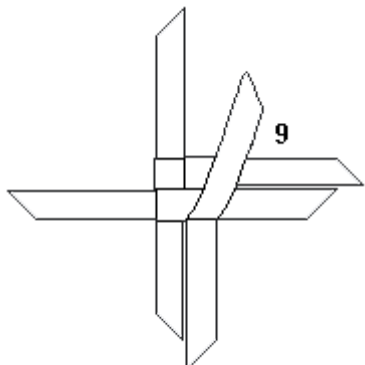

9 The third strip.

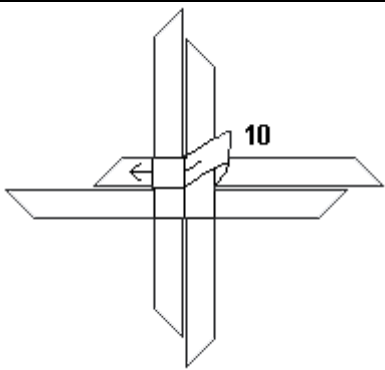

10 In the end, lock it by putting the forth strip through the first strip.

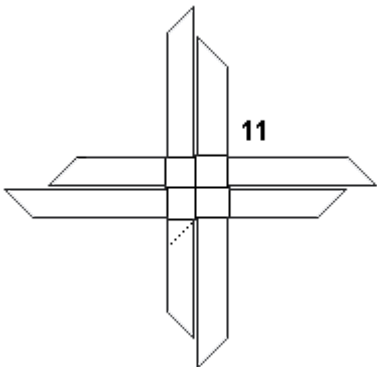

11 Bend the shortest end of the first strip.

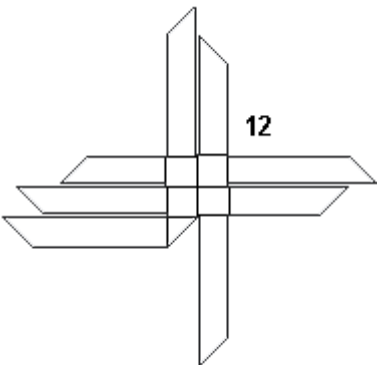

12 Fold the strip bagwards and out to the left, thereby creating a small triangle.

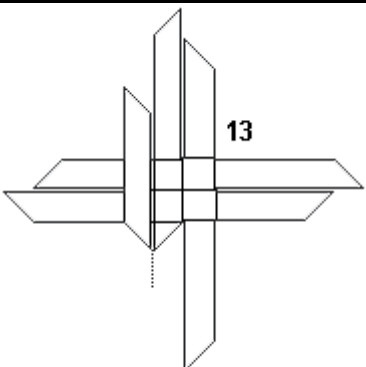

13 Bend the same strip 90 degrees upward, over the 2 horisontal strips.

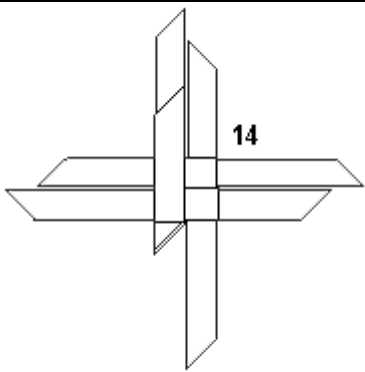

14 Continue by bending this strip over the 2 squares to the left.
The first tip is almost finished.

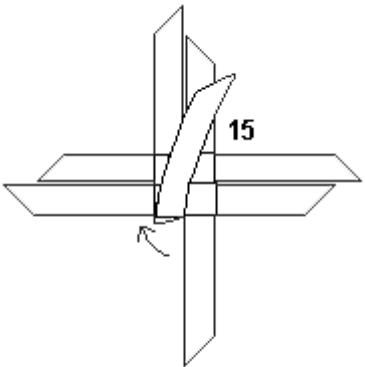

15 Bend the tip a little back.

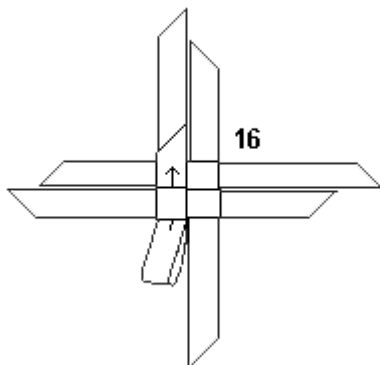

16 Take the free end of the strip and put it through the bottom left square.

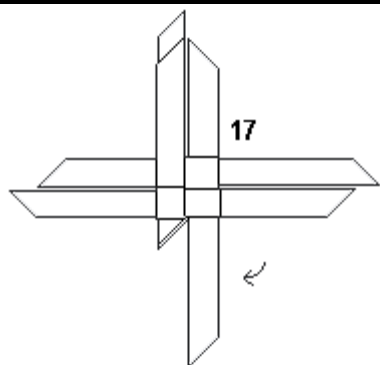

17 Pull the strip all the way through, so only the tip is visible.

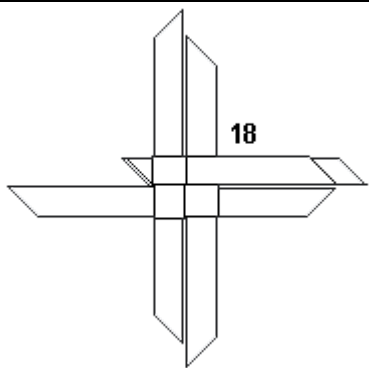

18 Turn the star 90 degrees as shown.

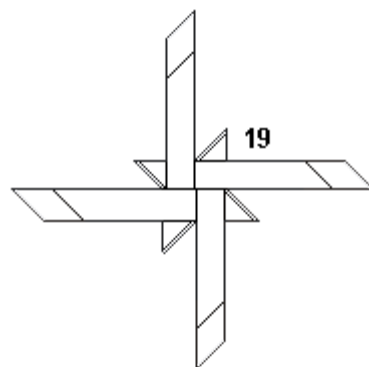

19 Continue by doing the same tip on the second, third and fourth strip.
See 11 to 18.

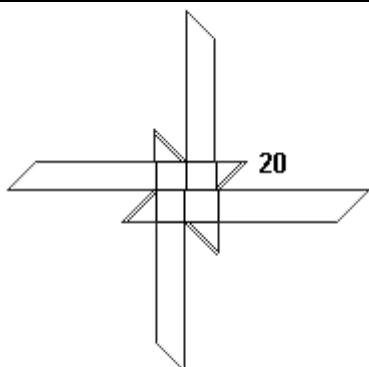

20 Turn the star to bring the back to the top.

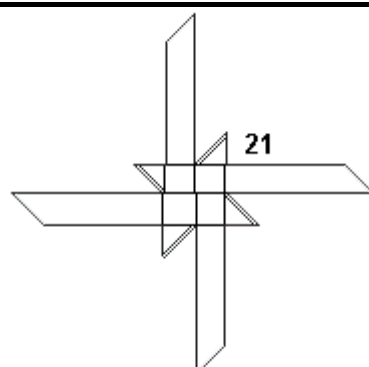

21 Do a tip on the 4 long strips.

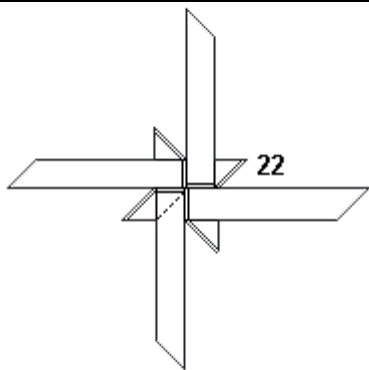

22 Turn the star again.
Bend the 4 ends over the 4 squares in the middle, in the opposite direction, as shown.

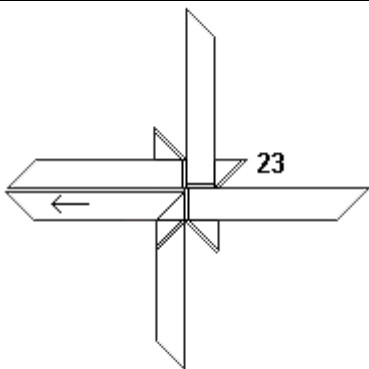

23 Bend the first strip 90 degrees to the left as shown.

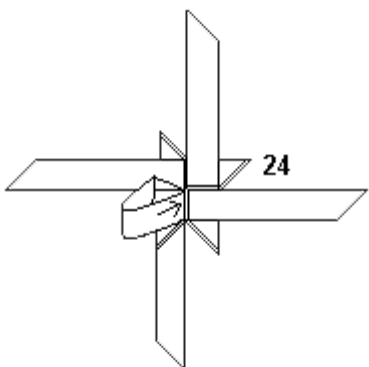

24 Bend the same strip upward towards the strip over this strip.
Put the free end of the strip under the opposite strip, and keep on showing it until it comes out of the tip.....

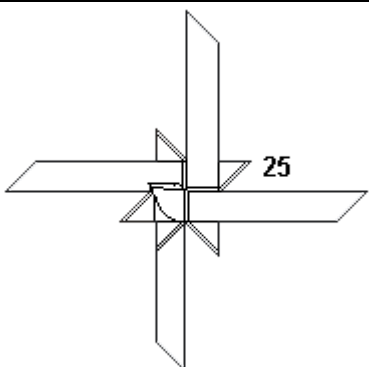

25 ... and creates a small cone shaped tip over the square in the middle.

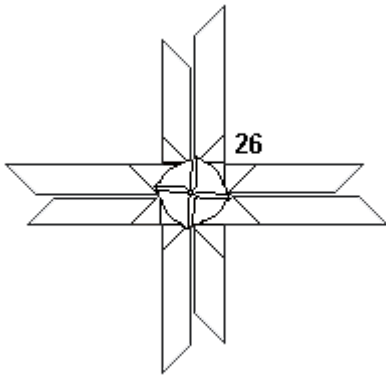

26 Repeat this with the other 3 strips. And then the other 4 cone shaped tips on the other side. In the end cut the strips that sticks out of the tips on the side away and the start is finished.

The plaited heart:

The simple type

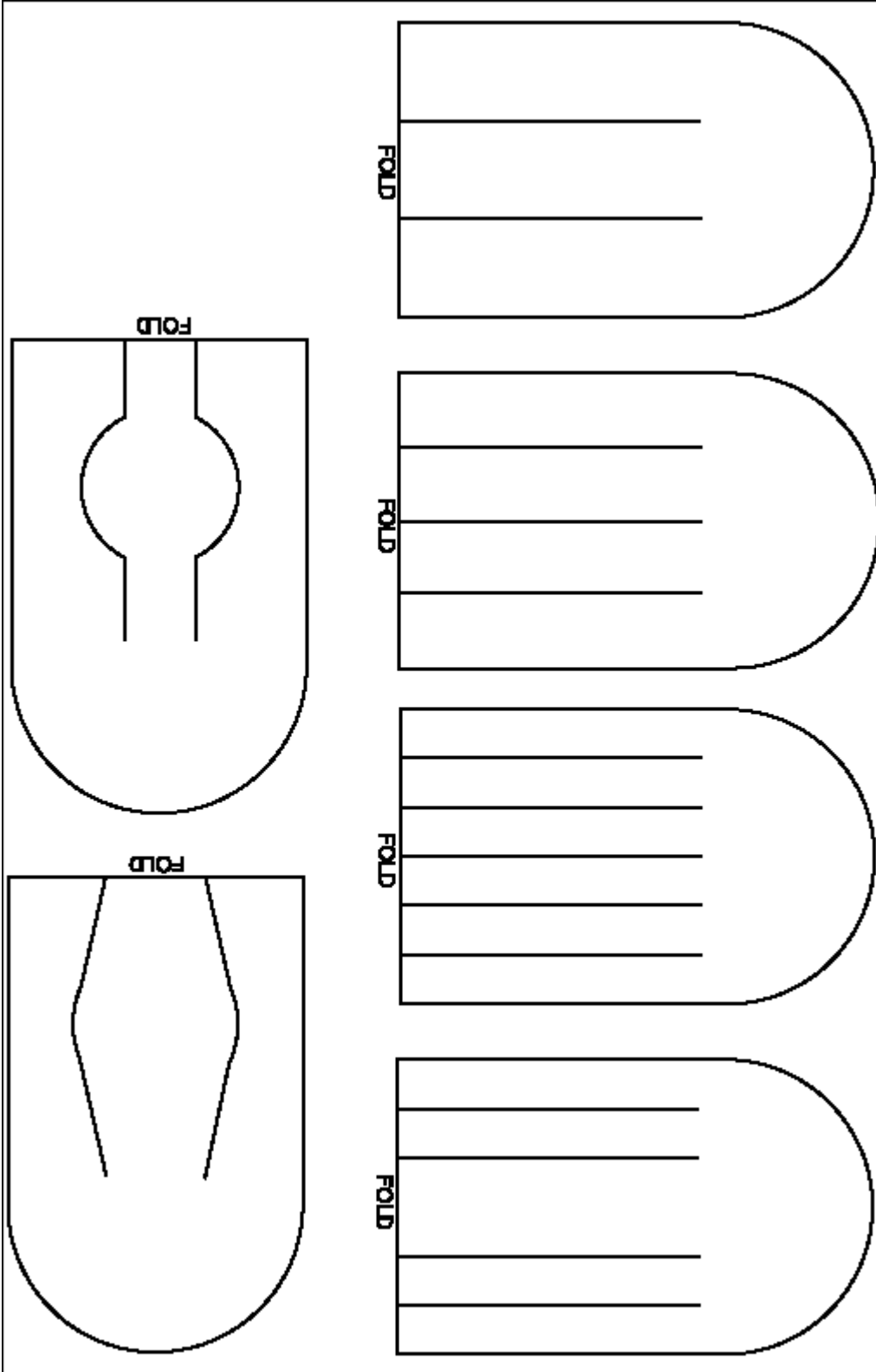

Howto:

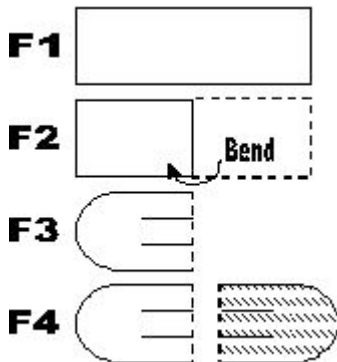

F1: Take a piece of paper. Preferably of the soft glimmer type and of different colour.

F2: Bend it at the middle.

F3: At the bend edge, cut so that you have at least 3 "tongues". The no bend end is cut round.

F4: Repeat F1-F3 with the other colour of paper.

F5:



F5: Now the two parts are to be plaited to together.

This is done by putting one "tongue" on part 1 inside and outside the tongues on the part 2 alternately.

When all tongues are plaited into each other the handle is cut from a single strip of paper and it is glued on.

The more complicated types

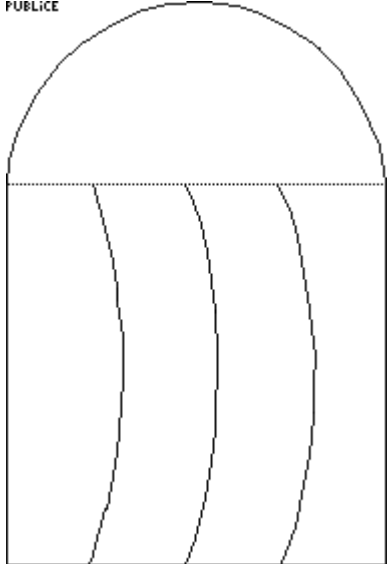
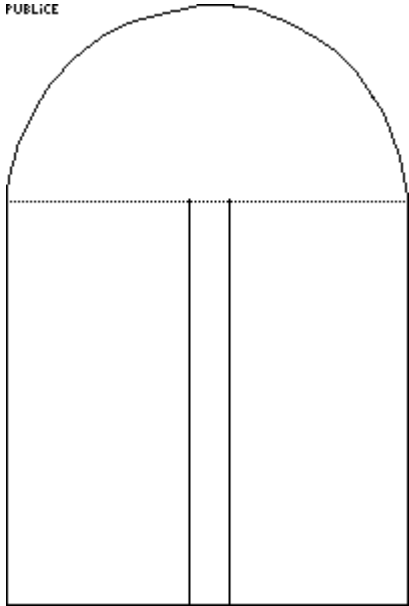

PUBLIC
1947

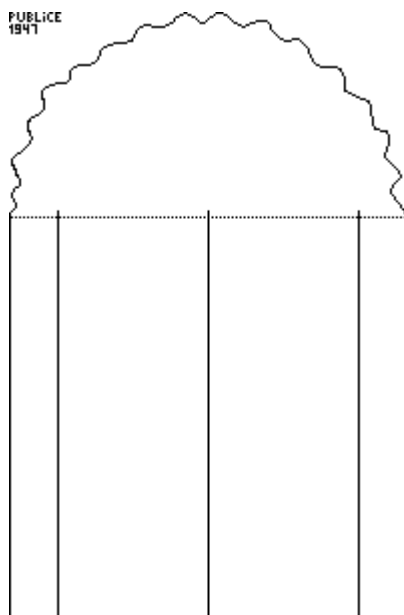

PUBLIC

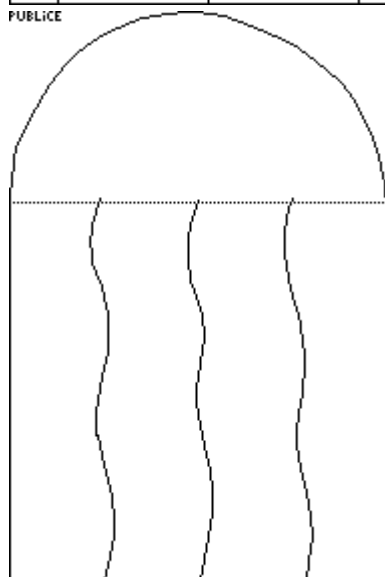

PUBLIC

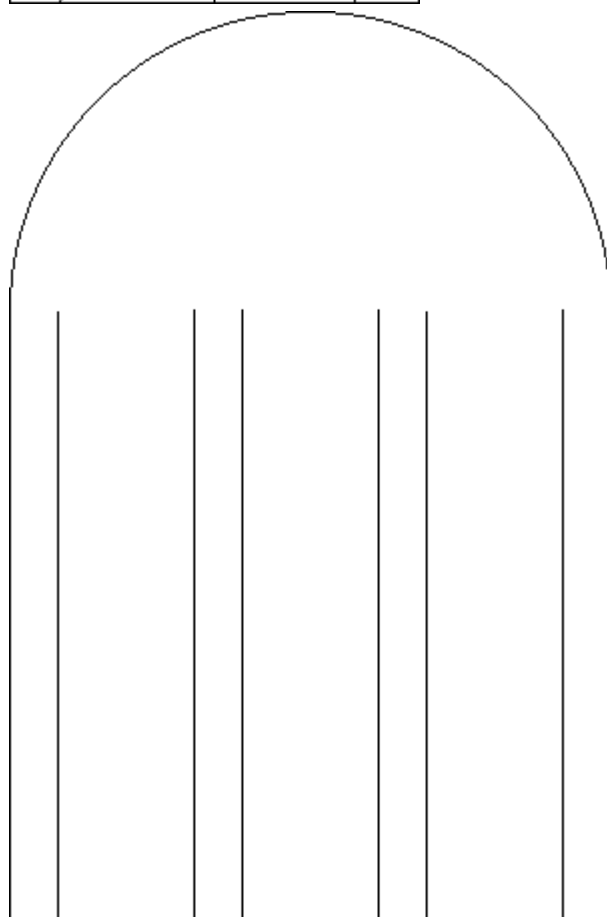
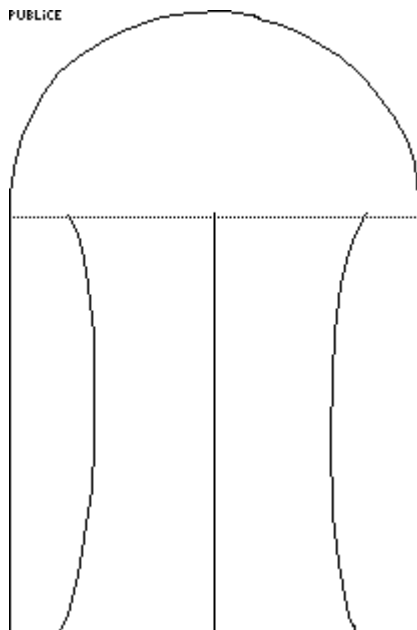

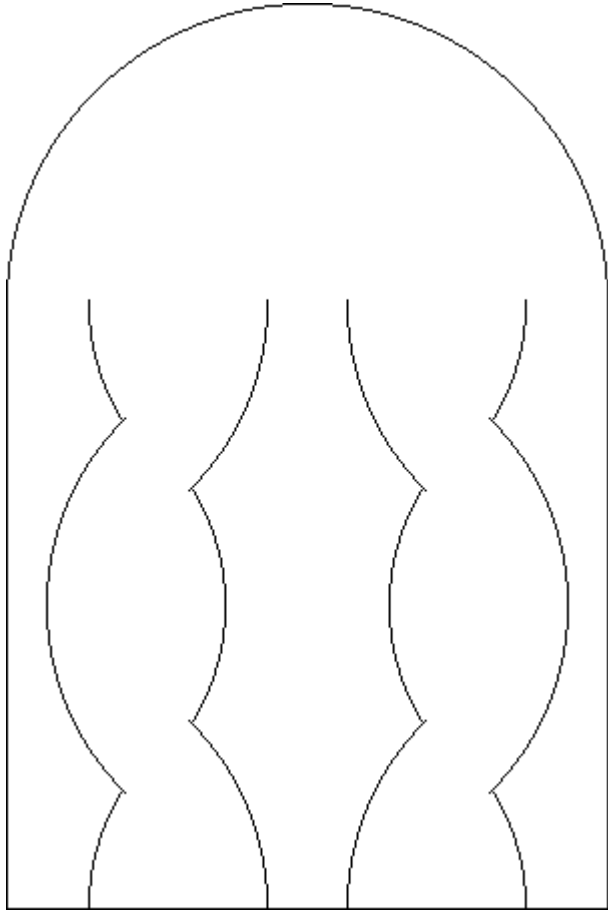

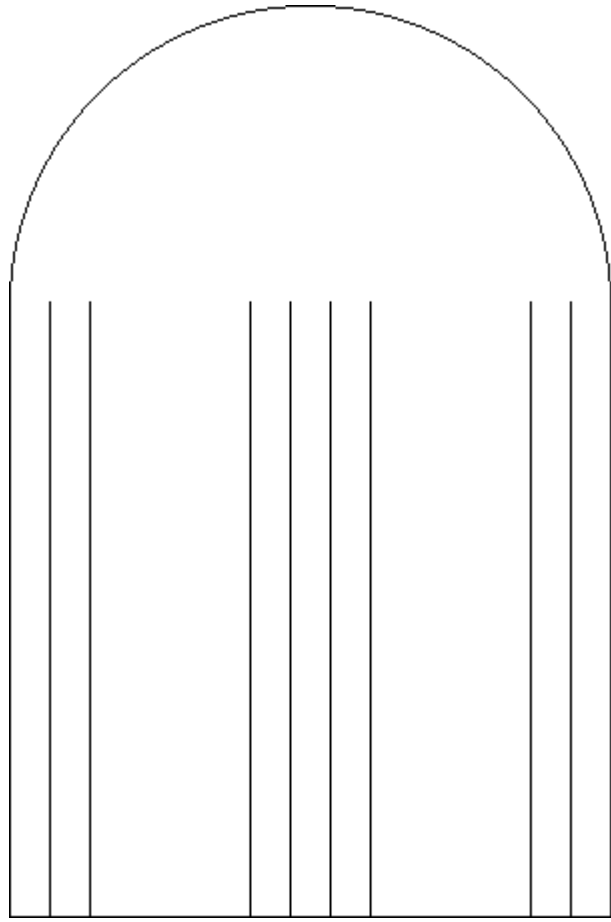
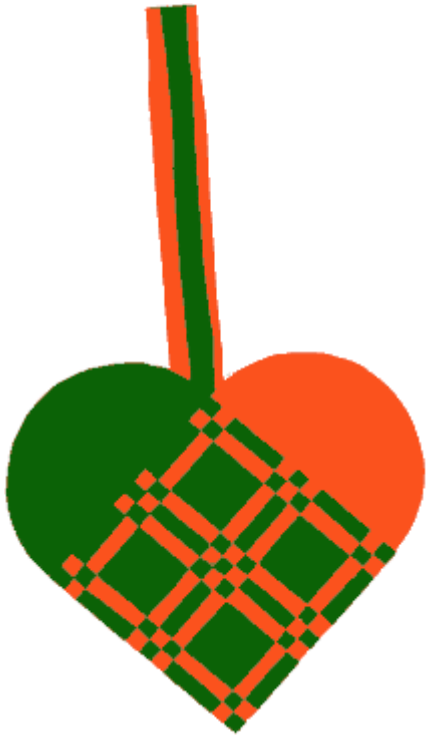

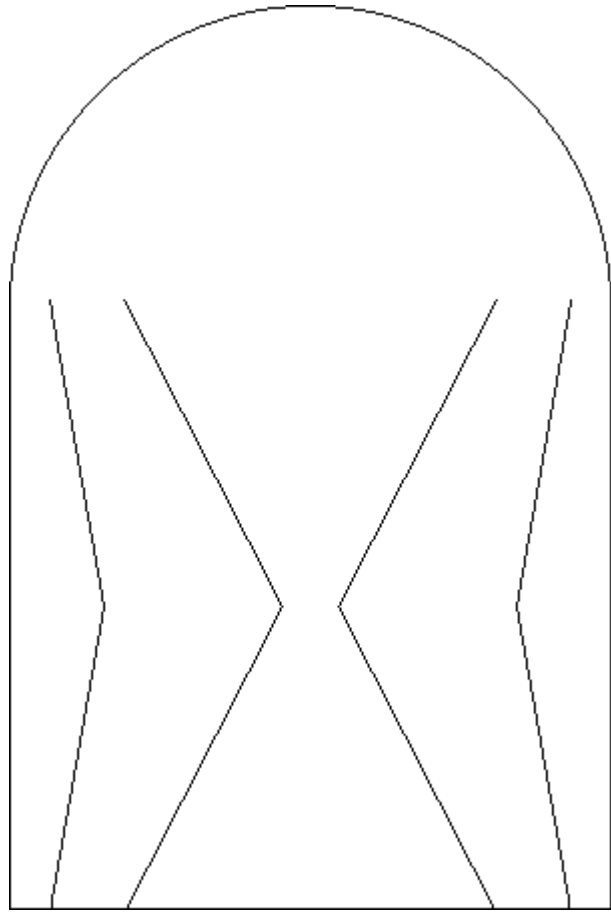

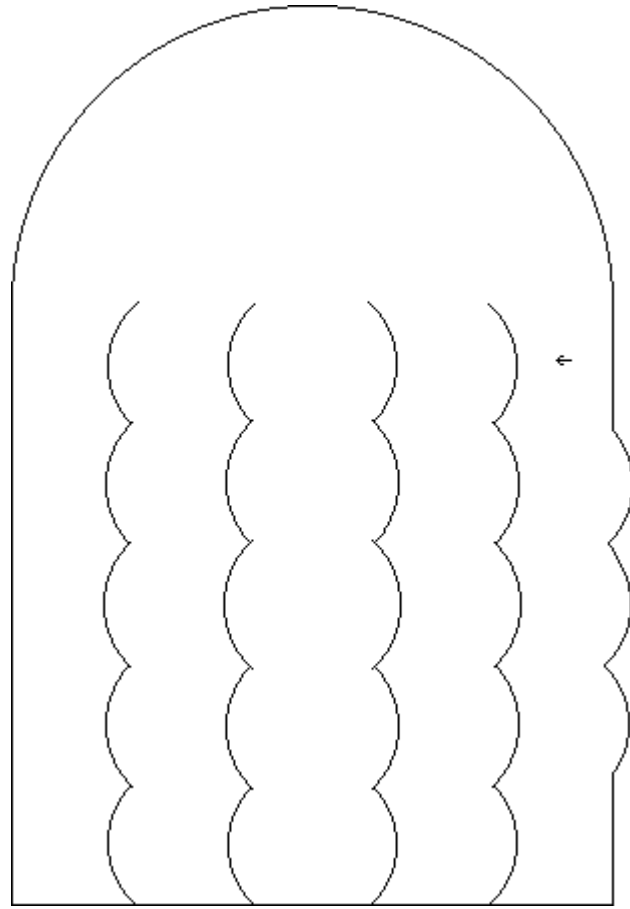

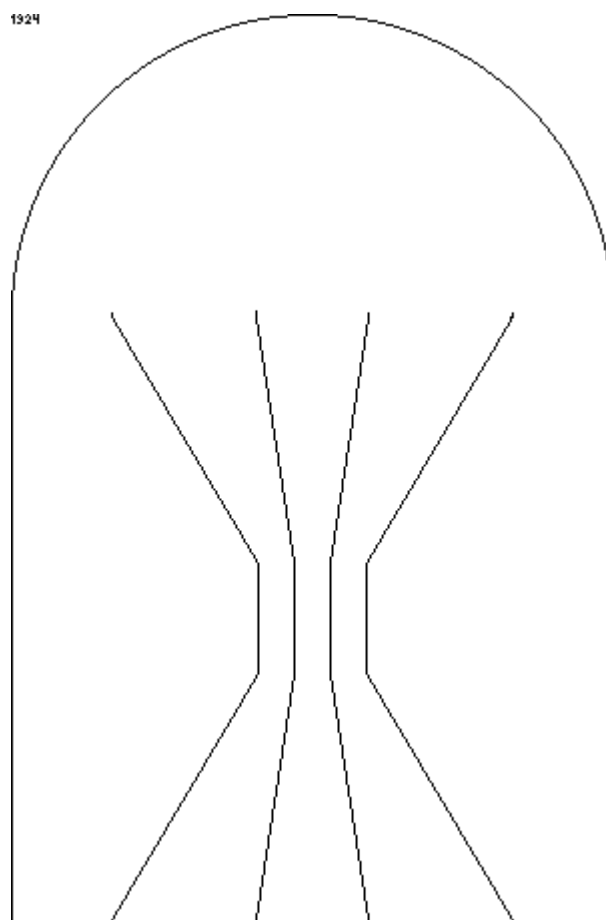

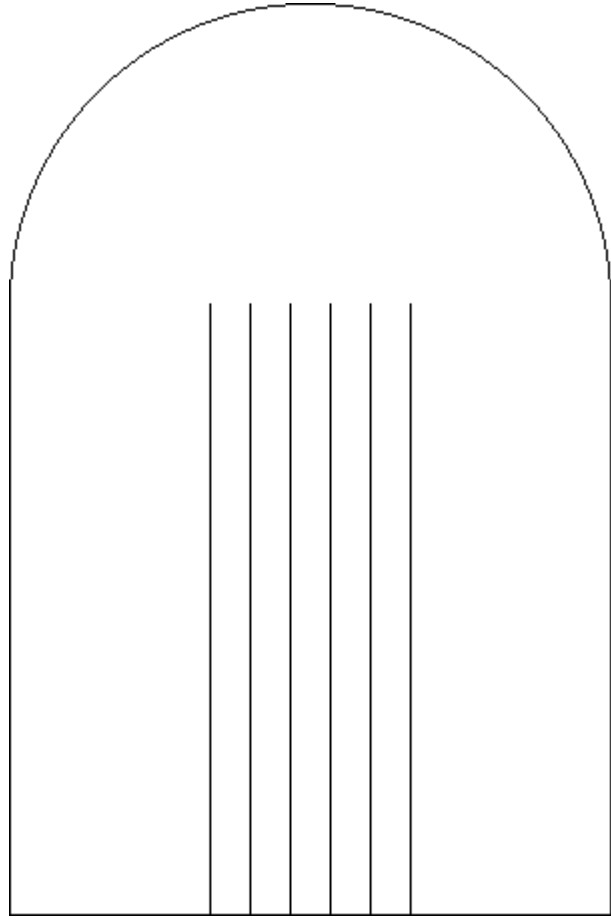

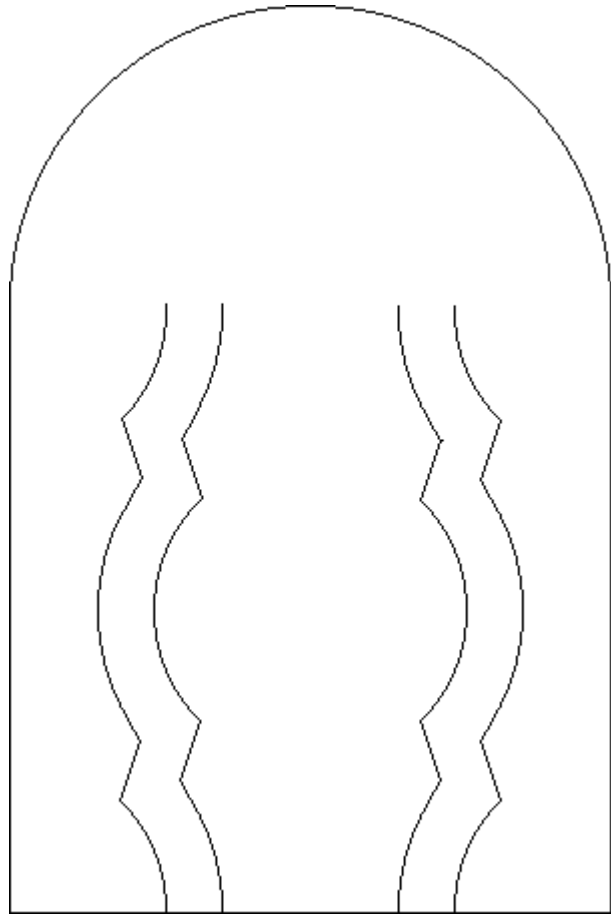

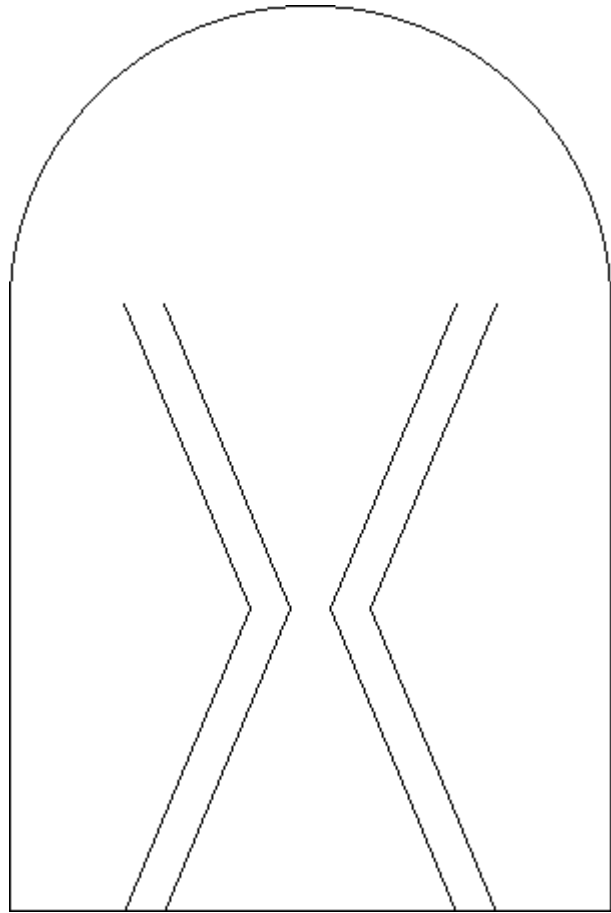

PETER
OLE
KVIINT

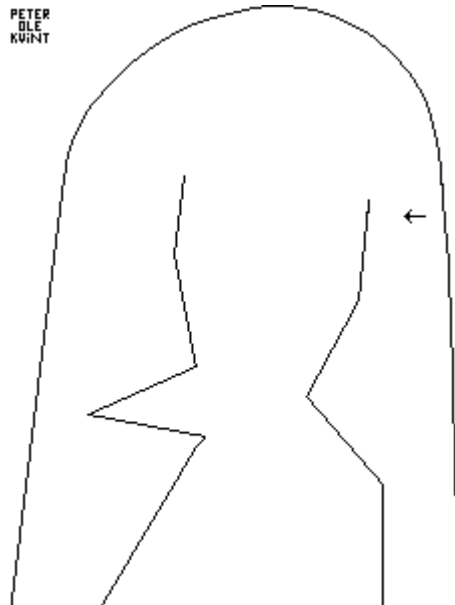

PETER
DLE
KUNST
2001

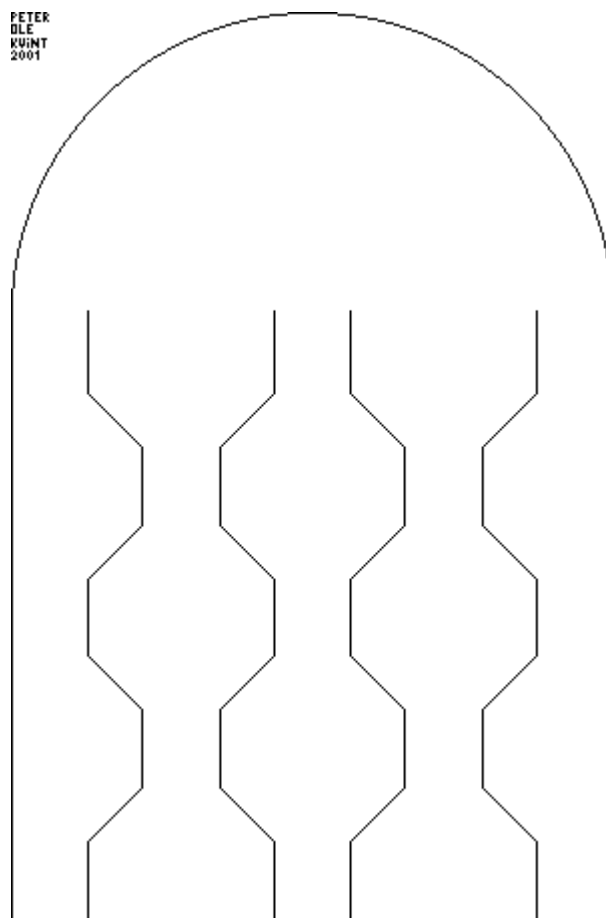
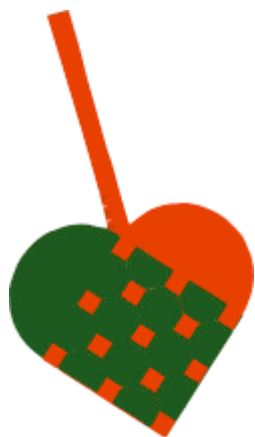

PETER
DLE
KUNST

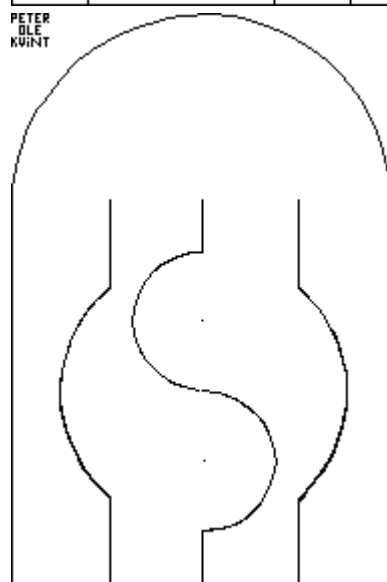



PETER
DLE
KVINT

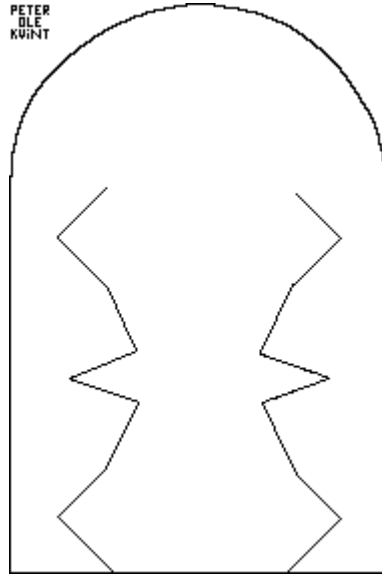

PETER
DLE
KVINT
2001

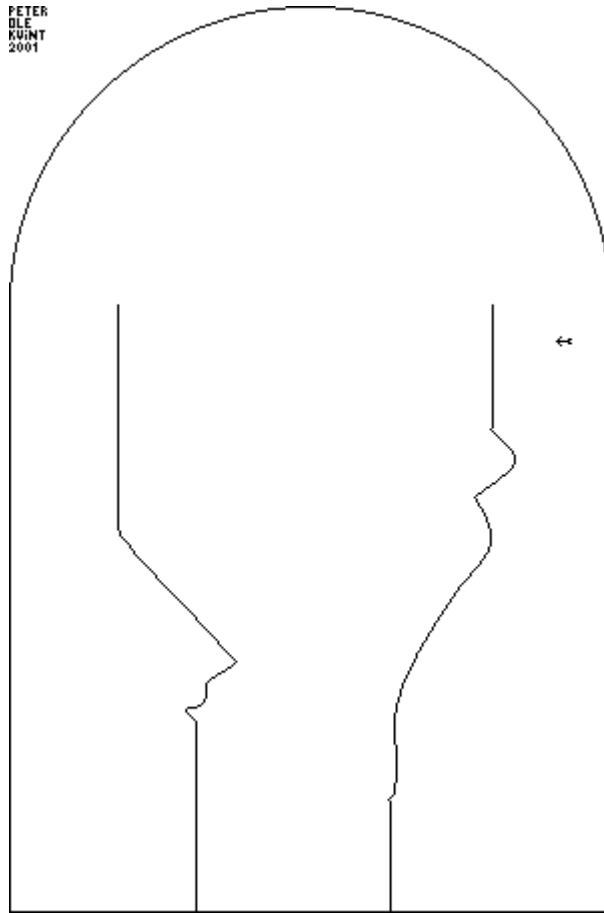

PETER
OLE
KVINT
2002

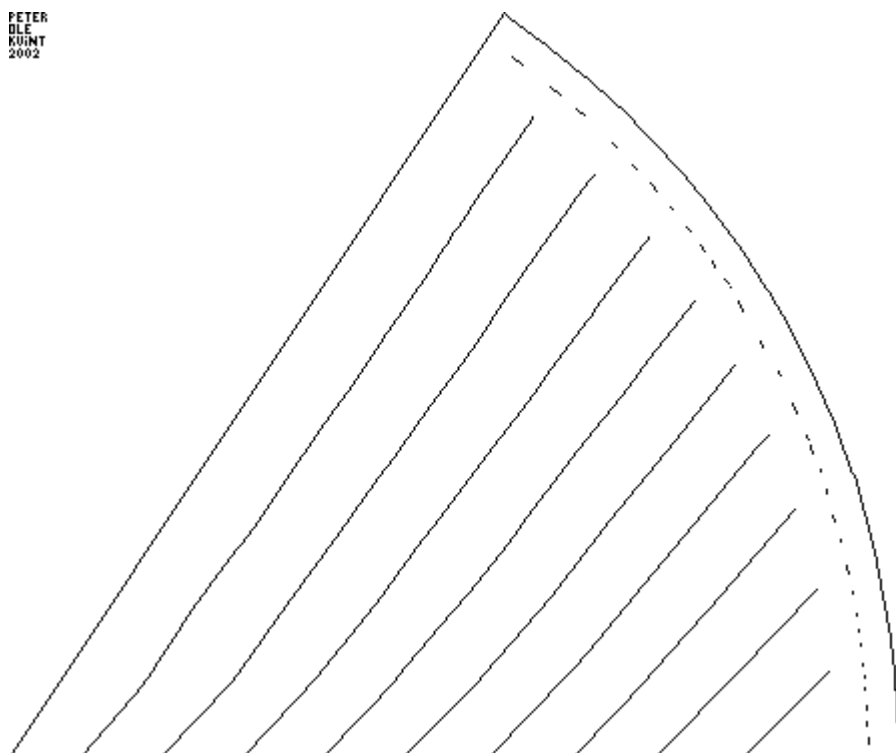

PETER
OLE
KVINT

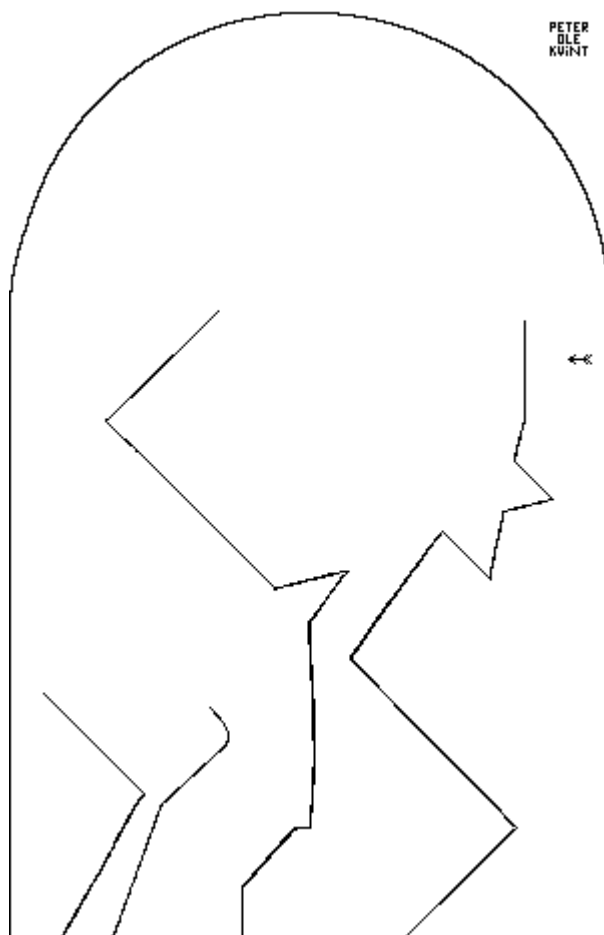



PETER
OLE
KVINT
2000

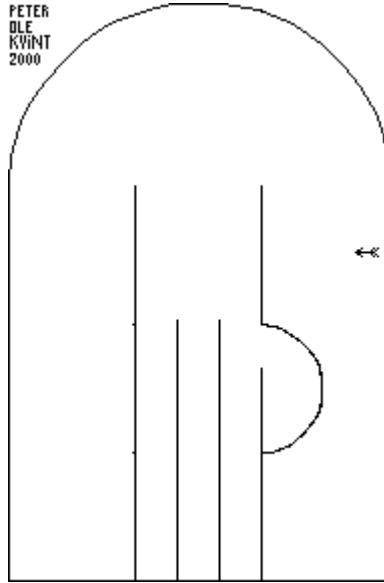

PETER
OLE
KVINT

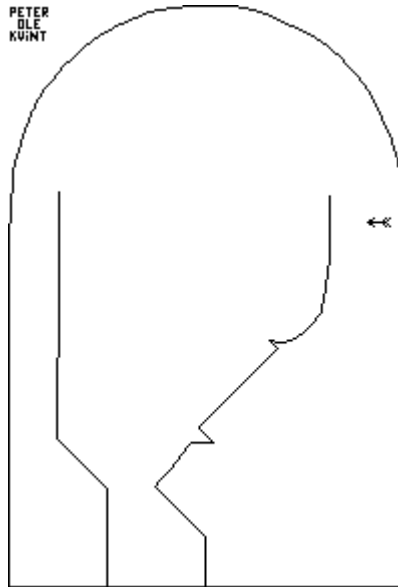

PETER
DE
KVINT
2000

